

Type MW

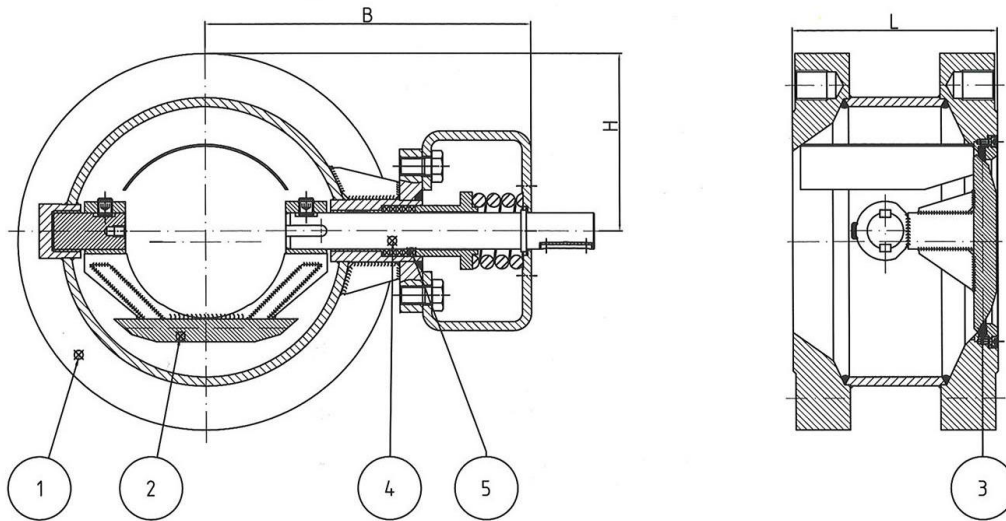

PN	Class	DN	Size	L	Bmax	Hmax	Antriebsanschluss Actuator connection	Gewicht Weight [kg]
10 - 40	150 - 300	50	2"	150	130	85	F5	8
		65	2 1/2"	170	145	100	F5	12
		80	3"	180	160	110	F7	16
		100	4"	190	180	130	F7	21
		125	5"	200	200	145	F12	28
		150	6"	210	225	165	F12	35
		200	8"	230	290	200	F14	47
		250	10"	250	325	240	F14	60
		300	12"	500	415	270	F16	75
		400	16"	600	460	350	F16	99
		500	20"	700	550	400	F16	124
		600	24"	800	630	470	F25	150
		700	28"	900	680	530	F25	174
		800	32"	1000	740	600	F30	199
		900	36"	1100	830	660	F30	224
		1000	40"	1200	900	710	F35	248
		1200	48"	1400	1050	870	F40	298
1400	56"	1600	1120	940	F40	360		
1600	64"	1800	1200	1100	F40	440		
1800	72"	2000	1300	1200	F40	540		
2000	80"	2400	1420	1320	F40	630		

Andere Ausführungen und Nennweiten auf Anfrage

